

# Middleware and Distributed Systems

## Transactions

---

Martin v. Löwis

# Terminology

---

- Financial Transaction (purchase, loan, mortgage, ...)
- Database Transaction: unit of interaction between a process and a relational database
- Atomic transaction: sequence of operations that should be atomic
  - not necessarily limited to databases - may involve regular files, or actions "in the real world"
  - all-or-nothing: should either completely succeed or completely fail
    - failure atomicity: should be atomic even in the presence of crashes
    - durability: changes should persist once transaction succeeds
  - isolation: concurrent transactions must not interfere

# ACID

---

- Härder and Reuter, Principles of Transaction-Oriented Database Recovery, Computing Surveys, 1983
- **A**tomicity: updates are all-or-nothing
- **C**onsistency: integrity is maintained across transactions
- **I**solation: intermediate states are not observable to other processes
- **D**urability: changes are not undone after a transaction completes
- **R**ecovery: system reverts to previous state in case of failure
- **C**oncurrency: allow concurrent operations even though they possibly might have conflicting effects
  - server needs to verify that actions are *serializable*

# Distributed Transactions

---

- client invokes operations on different servers
  - effects should be atomic across all servers
- flat vs. nested
  - flat: a client starts a transaction, then sequentially performs operations on multiple servers
  - nested: within a transaction, further transactions can be started; sub-transactions may run concurrently

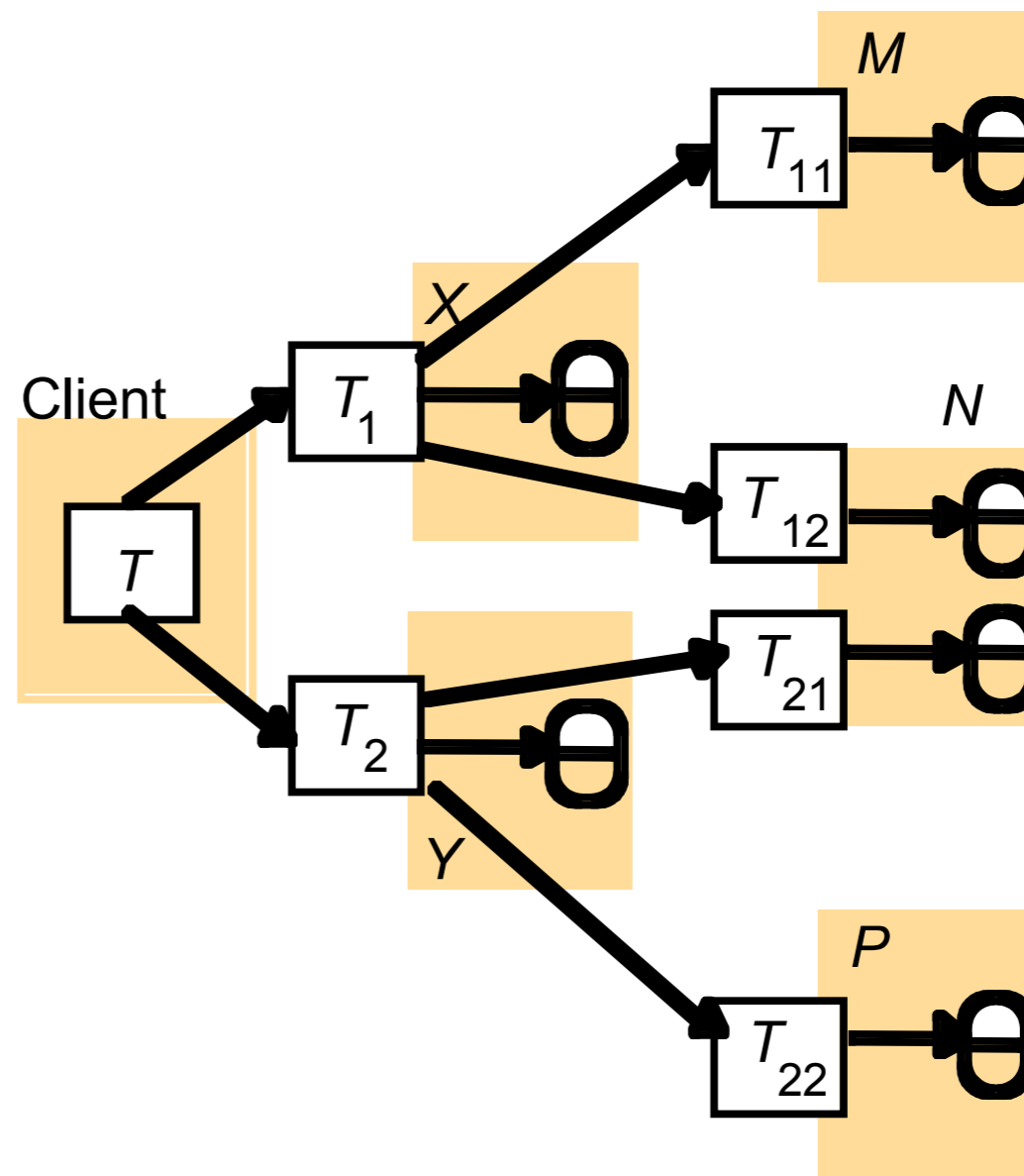
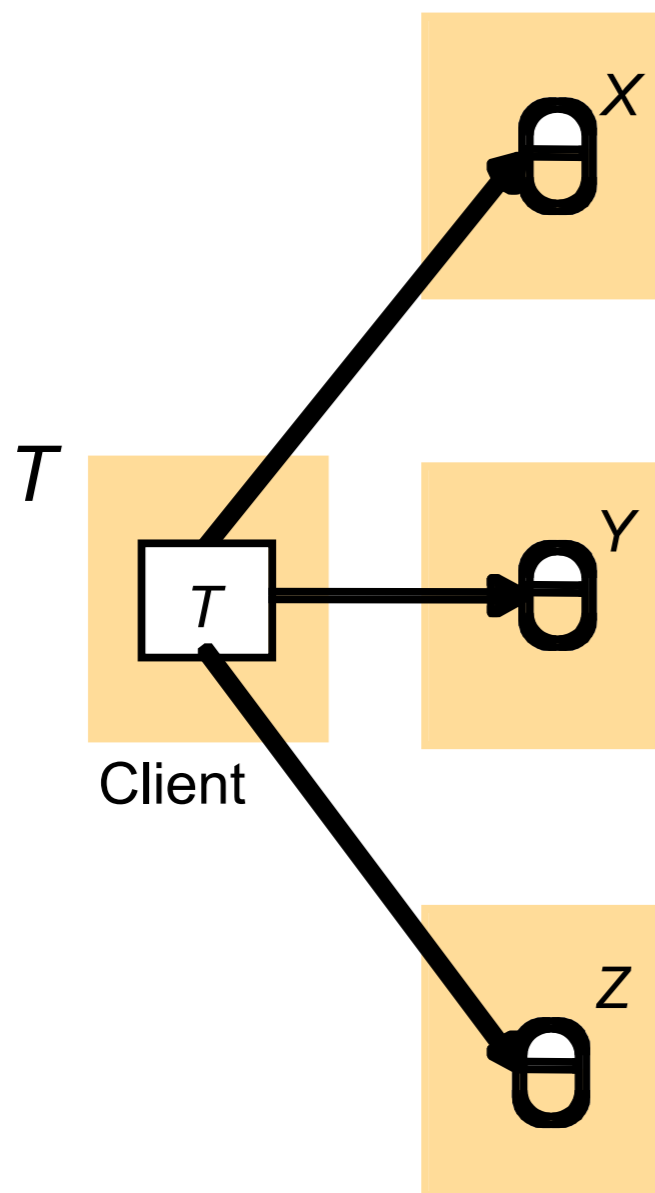

# Transaction Coordinator

---

- aka Transaction Manager aka Transaction Monitor
- allows identification of transaction, and keeps track of participants (*resources*) of a transaction
  - *openTransaction*: start a new transaction, returns transaction handle
  - *closeTransaction*: complete successfully
  - *abortTransaction*: discard all partial changes
  - *join*: include a reference to a participant (process) into the transaction
- client needs to communicate transaction handle to all participants
  - coordinator does not talk to participants during the transaction (only at the end)

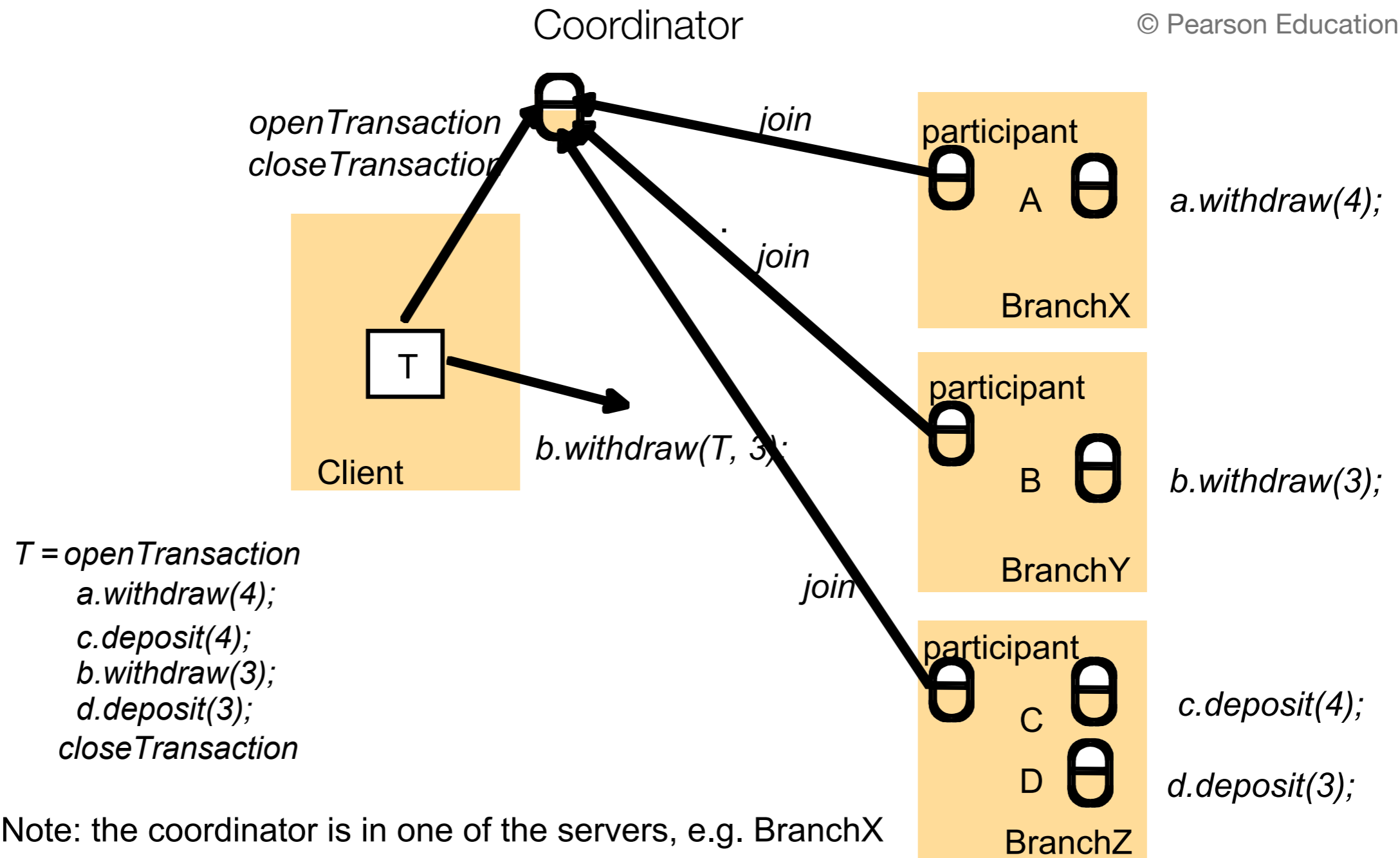

# Atomic Commit Protocols

---

- one-phase commit
  - server sends commit/abort messages to all participants
  - participant individually commits local changes
  - problem: what if a server fails to commit, e.g. when the server had to break a lock to resolve a deadlock with some other transaction
- two-phase commit (Gray 1978)
  - prepare phase: participants vote to commit or abort transactions
    - write *prepared* log entries, and enter *uncertain (in-doubt)* state
  - servers who voted to commit then must not change their minds
  - commit phase: participants all commit



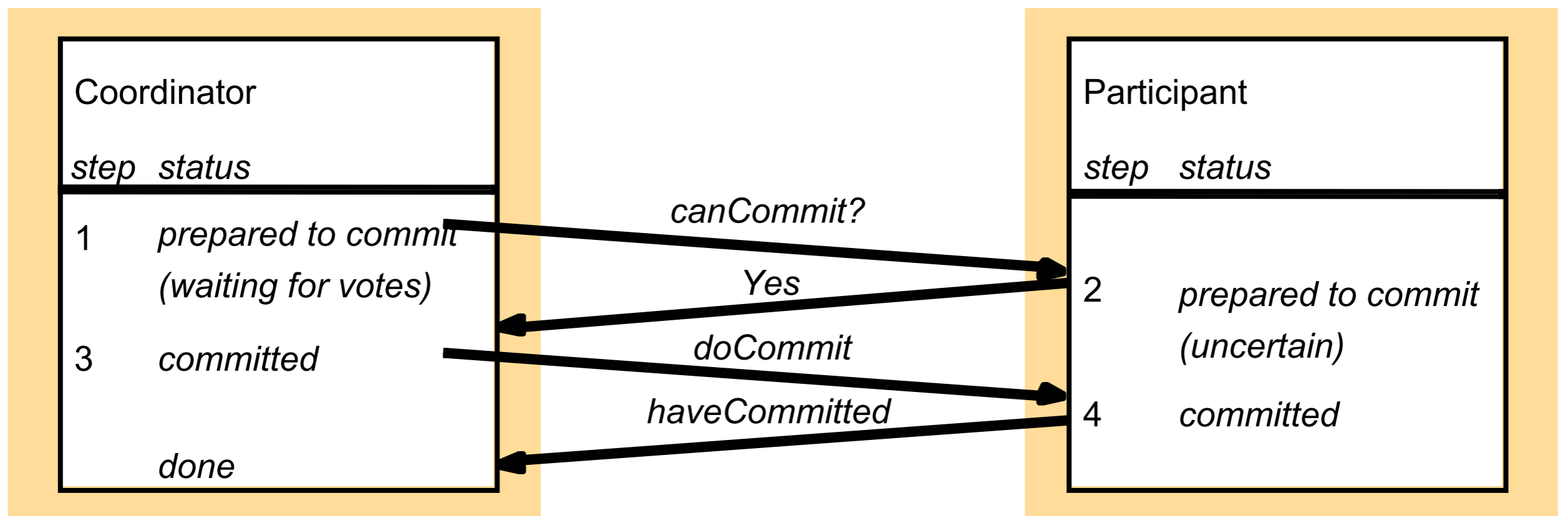

# Failures

---

- time-outs, server crashes, message loss
- server crash: server gets restarted from consistent state
  - information about ongoing transactions might have been lost, so prepare messages from coordinator result in aborts
  - in a crash after a "commit" vote, server needs to recover with prepare log
  - coordinator may abort transaction after participant timeout

# Failures (2)

---

- coordinator should maintain log of ongoing transactions, redo log during recovery
  - for started transactions without completed prepare phase: abort
  - if no vote was recorded for some participant: ask again
  - if abort was logged: redo abort
  - if commit was logged: redo commit
- coordinator crash: participant needs to find out global state, by asking restarted coordinator
  - before prepare: can safely abort transaction
  - after prepare (*uncertainty period*): need to wait for coordinator, or try to find other participants

# Correctness of 2PC

---

- **Safety:** if one process is in a final (committed/aborted) state, then either all processes are in the committed state, or all processes are in the aborted state
- **Liveness:** for a finite number of failures, 2PC will reach a final global state after a finite sequence of state transitions (i.e. messages sent)

# Nested Transactions

---

- Additional operations on coordinator:
  - *openSubTransaction(trans)*: nested transaction ID must include/refer to parent transaction
- Transaction status may be *committed*, *aborted*, or *provisional*
  - provisional commit is not durable, and visible only within the outer transaction (sub-transaction *joins* parent transaction)
  - server may lose information about provisional commits in a crash
- Parent transaction can be committed even if sub-transactions failed
  - Application needs to take appropriate corrective measures (e.g. retry)

# Nested Transactions: 2PC

---

- Hierarchic model: prepare calls are made recursively through the tree
  - intermediate nodes act as coordinators for their sub-transactions
  - entire transaction will abort if one participant aborts
- Flat model: top-level coordinator asks all coordinators of provisionally-committed transactions
  - if a parent transaction has already aborted, the sub-transaction must vote "abort": coordinator should send list of aborted transactions in prepare message

# XA

---

- X/Open specification for distributed transactions (1991)
- Application Program (AP)
- Resource Manager (RM)
- Transaction Manager (TM)
- not meant for communication (i.e. unspecified wire protocol)
  - suggests to use OSI DTP
  - XA is interface between RM and TM
- unit of work: global transaction
  - transaction branches on individual RMs, identified by XIDs

# xa.h

---

- C API to be used by the RM
- XA implementation provided by the TM vendor
- routines to be called by the RM: `ax_reg`, `ax_unreg`
- routines to be called by the TM (implemented by the RM, as function pointers):
  - `xa_open`, `xa_close`: initialisation
  - `xa_start`: create a new branch for the current thread, and associate it with given XID (or join current thread if XID was already started)
  - `xa_end`: dissociate current thread with XID
  - `xa_prepare`, `xa_commit`, `xa_rollback`: 2PC



# XA Implementations

---

- integrated into Java Transaction API (JTA), through `javax.transaction.xa.XAResource`
- TM Implementations
  - IBM Customer Information and Control Service (CICS)
  - Bea Tuxedo
  - Microsoft Transaction Server (also: OLE transactions)
- RM Implementations
  - Oracle, DB/2, MySQL, Berkeley DB, ...

# TX

---

- X/Open API for APs
- tx\_begin, tx\_rollback, tx\_commit
- tx\_info: returns XID

# CORBA Transaction Service

---

- OMG document formal/03-09-02: Transaction Service Specification, version 1.4
- both local API, and wire protocol
- IDL interfaces:
  - Current
  - Control
  - TransactionFactory
  - Terminator
  - Coordinator
  - Resource
  - Synchronization

# Current Interface

---

- gives access to current transaction, simplifies programming
- available as initial reference ("TransactionCurrent")
  - needs to be thread-local
- void begin() raises(SubtransactionsUnavailable);
- void commit(in bool report\_heuristics)  
raises(NoTransaction, HeuristicsMixed, HeuristicsHazard);
- void rollback()...
- Control get\_control();
- Control suspend(); void resume(in Control which)...

# TransactionFactory Interface

---

- implemented by TP monitor
- Control `create(in unsigned long time_out); // seconds`
- Control `recreate(in PropagationContext ctx);`

# Control Interface

---

- Terminator `get_terminator()`...
- Coordinator `get_coordinator()`...

# Terminator Interface

---

- `void commit(in boolean report_heuristics)..`
- `void rollback();`

# Coordinator Interface

---

- responsible for a single transaction
- access to status, transaction hierarchy
- creation of sub-transactions
- RecoveryCoordinator register\_resource(in Resource r)...
- void register\_synchronization(in Synchronization sync)...
- PropagationContext get\_txcontext()...



# Resource Interface

---

- `Vote prepare()` raises {`HeuristicsMixed`, `HeuristicsHazard`};
  - `VoteReadOnly`: no modifications made
  - `VoteCommit`, `VoteRollback`
- `void rollback()...`
- `void commit()...`
- `void commit_one_phase()...`
- `void forget()`;
  - only used after heuristic outcomes

# Synchronization Interface

---

- used to integrate transient state
- `void before_completion();`
  - invoked before the prepare step
  - object may start copying transient state to some resource
- `void after_completion(in Status s);`
  - invoked after complete or rollback

# Heuristic Decisions

---

- unilateral decisions, before consensus was achieved
  - typically in expectation of a likely outcome, and under some resource pressure (e.g. lock timeout)
  - only allowed/possible in the "uncertain" state
- reported as exceptions
  - HeuristicRollback
  - HeuristicCommit
  - HeuristicMixed
  - HeuristicHazard (not all outcomes known; the known ones are either all commit or all rollback)

# Transaction Context

---

- Automatically transmitted together with operation invocations
  - Alternatively: explicitly pass Control object to remote operation
- specific format for a single TP monitor unspecified; interoperable version encoded as a IOP::ServiceContext (ServiceId 0), as PropagationContext

```
struct TransIdentity{
    Coordinator coord;
    Terminator term;
    otid_t otid; // compatible with XA XID
};
struct PropagationContext{
    unsigned long timeout;
    TransIdentity current;
    sequence<TransIdentity> parents;
    any implementation_specific_data;
};
```

# Policies

---

- objects need to express their ability to participate in a transaction
- OTS 1.0, 1.1: Inheritance from empty interface TransactionalObject
- OTS 1.2: IOR contains component indicating policy of object (OTSPolicy)
  - requires: object must be invoked in the context of a transaction
  - forbids: object must not be invoked in a transaction
  - adapts: can live with or without transaction
- CORBA messaging: communication may go through a broker breaks transaction boundary
  - InvocationPolicy specifies whether target object requires SHARED transactions, UNSHARED transactions, or either kind
- Server code sets policy on POA creation

# OTS Implementations

---

- Java Mapping: JTS (Java Transaction Service) is based on OTS 1.2
  - BEA Jolt
  - VisiBroker ITS (Integrated Transaction Service)
- BEA Tuxedo (for C++)
- Orbix E2A Application Server Platform
- Encina++ (IBM TXSeries)
- OpenORB transaction service
- ...

# Related Technology

---

- Persistent State Service (PSS) (formal/02-09-06)
  - data definition in PSDL
- Additional Structuring Mechanisms for OTS (formal/05-01-01)
  - Activity Service
  - support for long-running transactions
    - ACID properties not necessary; resources are committed before end of activity
  - additional transaction concepts: activity, compensation