

Eingebettete Betriebssysteme 20/21
Self Driving Carrera Cars
Tom Braun, Björn Daase, Leon Matthes

Current Status

[Self Driving Carrera Cars](#)

Circuit Diagram

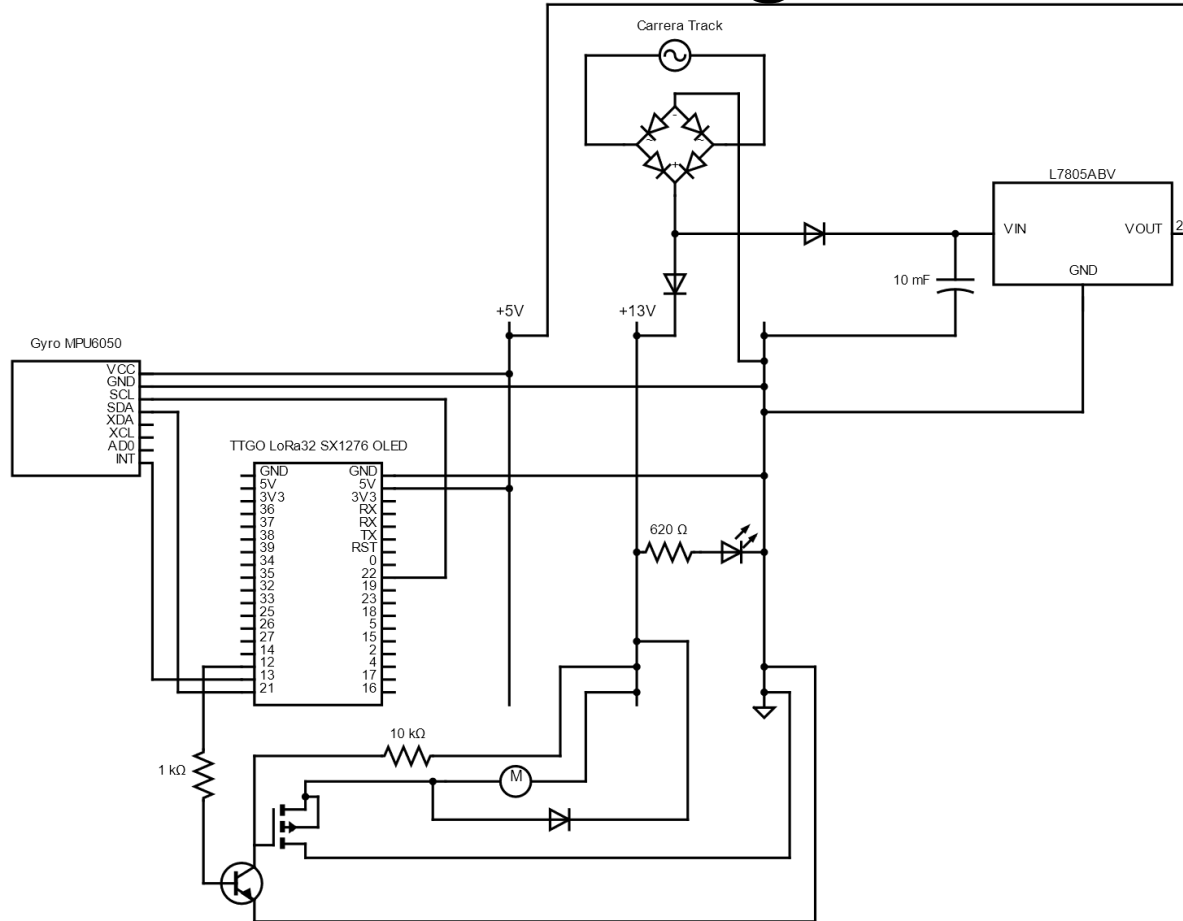

Curve Detection

[Curve Detection on Self Driving Carrera Car](#)

Idea

- Use accelerometer data to map the track
- Allows to drive with foresight

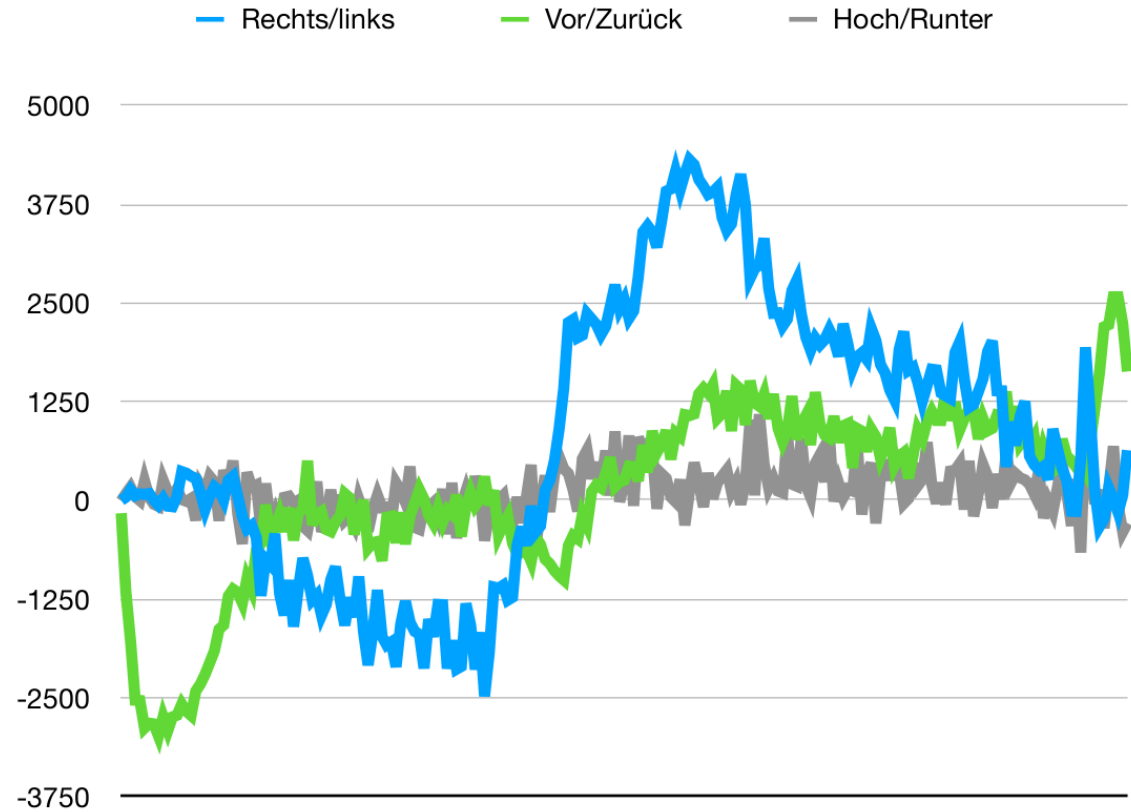

Current Challenges

- Accelerometer currently provides random data after a undetermined period of time
 - Can be temporarily fixed by reinitializing
- Mapping sensor data to stored track data
- Little memory on Arduino Nano prohibits storing of uncompressed sensor data