

Unit 9: Windows 2000 Networking

9.1. Networking Components in Windows 2000

AP 9/01

Networking in Windows 2000

Design goals

- Integral, application-transparent networking services
 - Basic file and print sharing and using services
- A platform for distributed applications
 - Application-level inter-process communication (IPC)
- Windows 2000 should provide an expandable platform for other network components
- References:
 - Ralph Davis, „Windows NT Network Programming“, Addison-Wesley, 1996,
 - MSDN, Helen Custer „Inside Windows NT“, MS Press, 1993.
 - Solomon, Russinovich, „Inside Windows 2000“, MS Press, 2000

AP 9/01

Roots of Windows 2000 Networking

- MS-DOS 3.1:
 - Added file-locking and record-locking to FAT file system
 - Product: Microsoft Networks (MS-NET; 1984)
 - Uniform naming convention (UNC): NET USE X: \\SERVER\SHARE
- MS-NET established some traditions:
 - Redirector traps I/O requests destined to remote file, directory, printer
 - MS-NET redirector sends request to remote server
 - NT networking supports multiple redirectors
- Server Message Block protocol (introduced in MS-NET)
 - NetBIOS interface (API) to pass I/O requests in SMB format
- Network Server
 - Accepts and handles SMB requests; peer-to-peer networking
- LAN Manager
 - Network domains; share account/security info

AP 9/01

OSI Reference Model

- Computer network is an *interconnected collection of autonomous computers* (Tanenbaum)
- Standardize and integrate networking software:
 - International Standards Organization defined a software model for sending messages between machines
- Open Systems Interconnection (OSI) reference model
 - Idealized scheme
 - Each layer on one machine assumes that it is „talking“ to the same layer on the other machine
- Each layer provides services to higher layers and abstracts from implementation of services at lower layers

AP 9/01

OSI Reference Model (contd.)

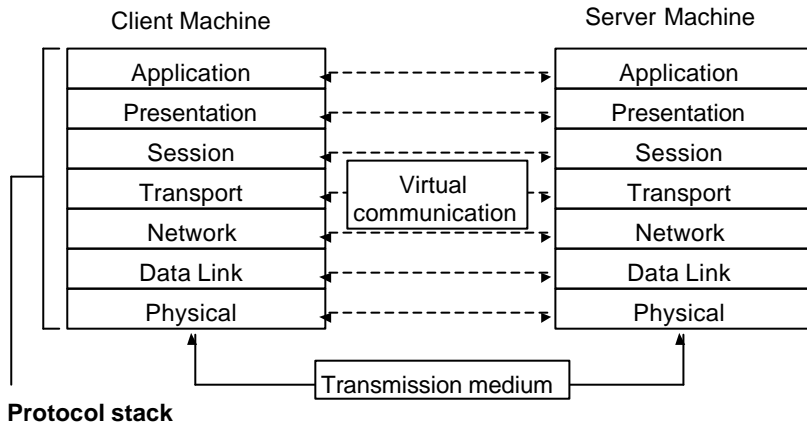

AP 9/01

Layers in the OSI Model

- Application layer (7)
 - Information transfer between network apps., Initiation of data exchange
 - Security checks, identification of participating machines
- Presentation layer (6)
 - Data formatting, data compression, encoding, etc.
- Session layer (5)
 - Manages connection between cooperating applications
 - High-level synchronization and monitoring: who is talking/listening
- Transport layer (4)
 - Divides messages into packets, assigns sequence numbers
 - Segmentation, assembly; hides changes in networking hardware

AP 9/01

Layers in the OSI Model (contd.)

- Network layer (3)
 - Routing, congestion control, internetworking
 - Highest layer, that understands network topology (physical configuration of machines, type of cabling, bandwidth limits)
- Data-link layer (2)
 - Transmits low-level data frames, waits for acknowledgements
 - Re-transmission of lost packets
- Physical layer (1)
 - Passes bits to the network cable/physical transmission medium

AP 9/01

OSI Model and NT Networking

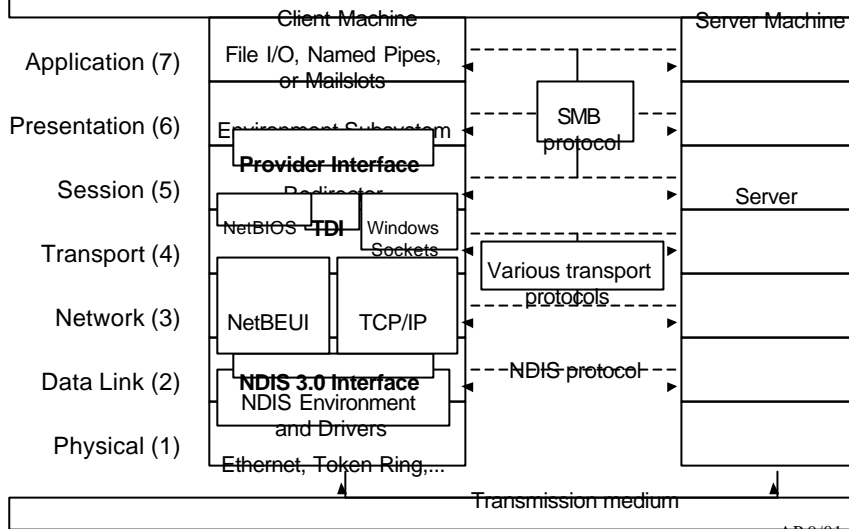

AP 9/01

Client-Side View of Network I/O

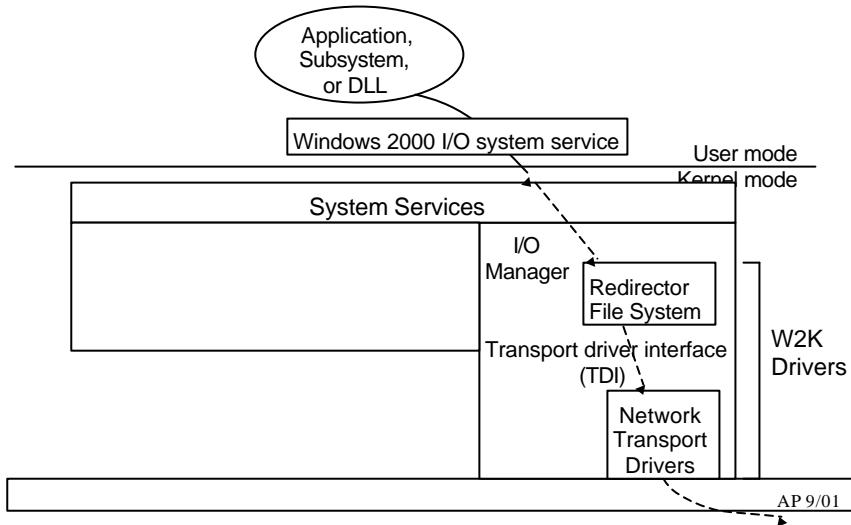

Server-side View of Network I/O

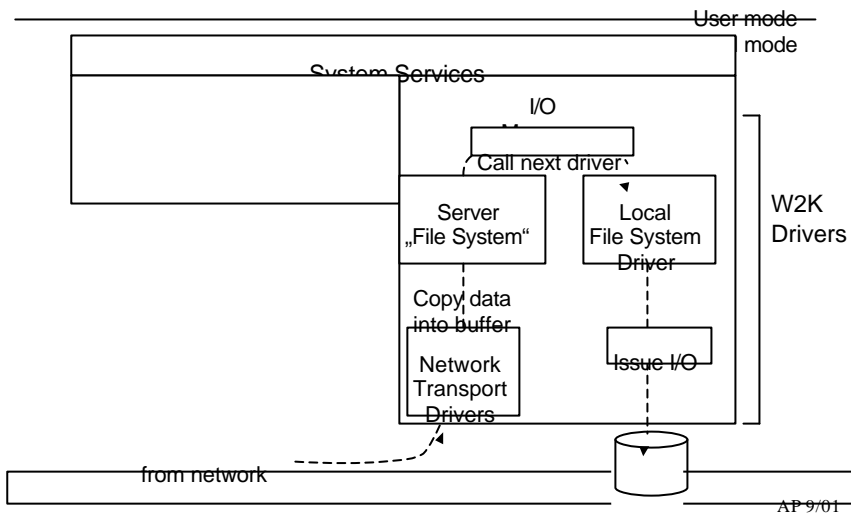

Network APIs

- Win32 I/O API
 - Open, close, read, write with UNC names referring to remote machines
- Win32 network (WNet) API
 - Browse file systems via LAN Manager, NetWare, VINES, nfs,...
- Win32 named pipe and mailslot APIs
 - Message passing between apps., broadcasting
- NetBIOS API
 - Backward compatibility for MS-DOS, 16-bit Windows, OS/2 apps.
- Windows Sockets API
 - 16/32-bit UNIX-style standard interface for networking
- Remote Procedure Call (RPC) facility
 - Compatible with OSF's Distributed Computing Environment (DCE) RPC

AP 9/01

Routes to the Network

- Each API finds its way to the network through a different route
 - Win32 I/O routines call NT I/O system services; I/O manager sends IRPs to redirector
 - Sockets API and NetBIOS API are DLLs, that call NT I/O services; I/O manager sends IRPs to Sockets and NetBIOS drivers
- Services – comparable to UNIX daemon processes
 - *Service controller* manages loading and starting of NT services
 - Services may export an API to support specific functions, e.g.:
 - Administering built-in redirector (LAN Man *WS service*, *Server service*)
 - Sending alert messages (disk full) to logged-on users (*alerter service*)
 - Receiving messages (print job notification) from other systems (*messenger service*)

AP 9/01

Routes to the Network (contd.)

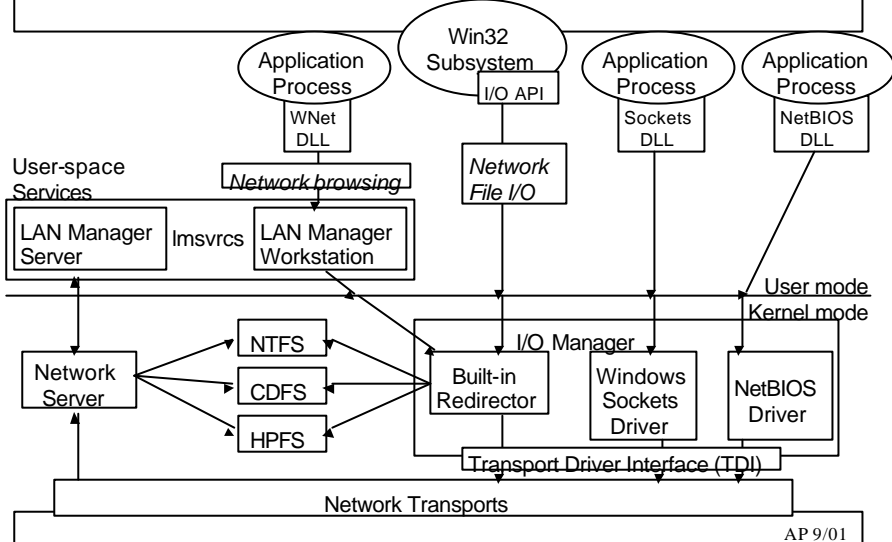

Built-in Networking Components

- Redirector and network server:
 - Introduced with MS-NET (assembly lang.);
 - completely re-written (C) for Windows NT/2000
 - Implemented as loadable file system drivers
 - Can coexist with other vendor's redirectors and servers
- Implemented as file system drivers, that means:
 - Part of the Windows 2000 executive
 - Access to I/O manager's driver interfaces
 - Ability to call cache manager functions directly
 - I/O manager's layered model reflects layering of network protocols
 - Redirector/server can be layered on top of any transport protocol driver – modular components

Redirector/Server Operation

- **Compatibility:**
 - Works with existing MS-NET & LAN Manager servers (MS-DOS, OS/2, Windows)
 - Can access remote files, named pipes, printers
- **Initialization:**
 - Driver's init routine creates object `\Device\Redirector`
 - Registers dispatch routines for driver operations (open, close, read,..)
- **Reliability:**
 - Periodic reconnect to servers; mask transient faults, if possible
 - Maintains tables of open files; reopens files on reconnect
- **Asynchronous operation:** (support for asynch. I/O)
 - Return immediately to user-space process
 - Employ thread in initial system process to wait for I/O completion

AP 9/01

Resolving a Network Filename

Extend the reach of local I/O to include remote resources

- All these resources are objects
- Object manager gets involved in opening files

1. User assigns drive letter NET USE T: \\TOOLSERV\TOOLS; workstation service creates symbolic link
2. Win32 app. opens file T:\editor.exe
3. Win32 subsystem. Translates name to NT object `\DosDevices\T:\editor.exe`; calls NT executive to open file
4. Object manager substitutes symbolic link to `\Device\Redirector`

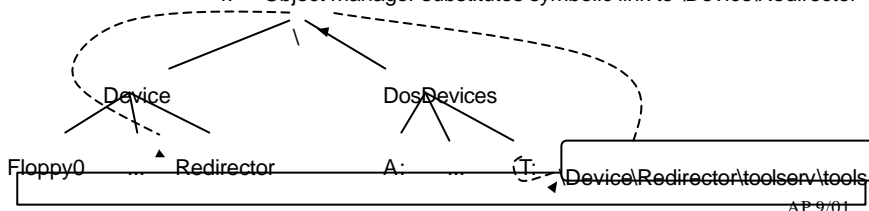

AP 9/01

Name Resolution (contd.)

- **Device objects:**
 - Launching point into an object namespace that is not controlled by the NT object manager
 - Object manager calls parse method associated with the device object
- **In our case:**
 - Method is an I/O manager routine that calls redirector
 - Redirector builds SMBs (Server Message Blocks)
 - Remote SMB server opens file \editor.exe on \\TOOLSERVER\TOOLS
- **Locally:**
 - NT object manager creates local file object to represent opened file
 - Returns object handle to caller; subsequent op. go directly to redirector
- **Remote object namespace:**
 - Contains \Device\Server; used to manage the server by name
 - Not used when server receives request

AP 9/01

Open Architecture

- Redirector, network server, transport drivers can be loaded/unloaded dynamically
 - A variety of such components can coexist
- Windows 2000 supports multiple networks:
 - Access to file systems for resource connection, network browsing, and for remote file and device I/O through common Win32 WNet API
 - Multiple network transport protocol drivers can be loaded simultaneously; redirectors access them through common interface
 - Supplies interface and environment (NDIS 3.0) for network card drivers to access NT transport drivers
- Access to remote files systems via:
 - **Multiple provider router (MPR)** – a DLL which determines which network to access when an app uses Win32 WNet API
 - **Multiple UNC provider (MUP)** – a driver that determines which network to access when an app uses Win32 I/O API to open remote files

AP 9/01

Multiple Provider Router (MPR)

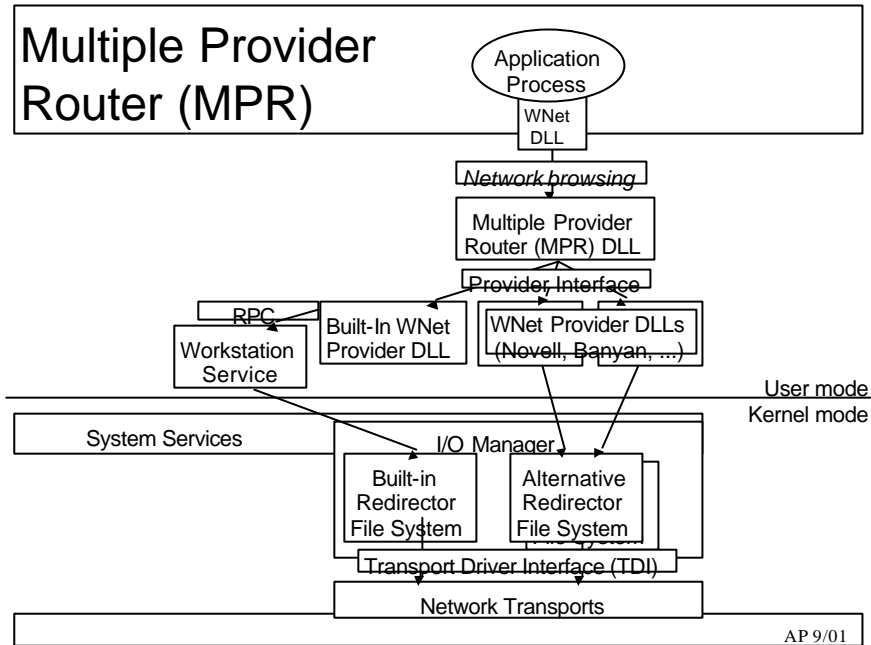

Multiple UNC Provider (MUP)

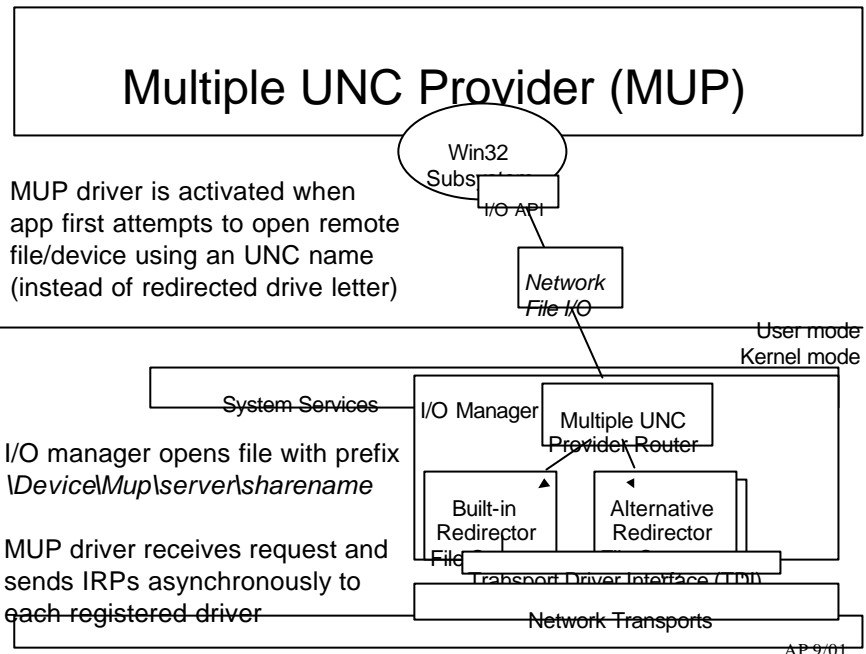

Transport Driver Interface

- Transport protocols are implemented as drivers
- NT provides a single programming interface for redirectors and other high-level network drivers
 - Transport Driver Interface – TDI – allows redirectors and servers to remain independent from transports
- A single version of a redirector or server can use any available transport mechanism
- TDI is asynchronous,
 - Implements generic addressing mechanism
 - Variety of services and libraries

AP 9/01

Transport Driver Interface (contd.)

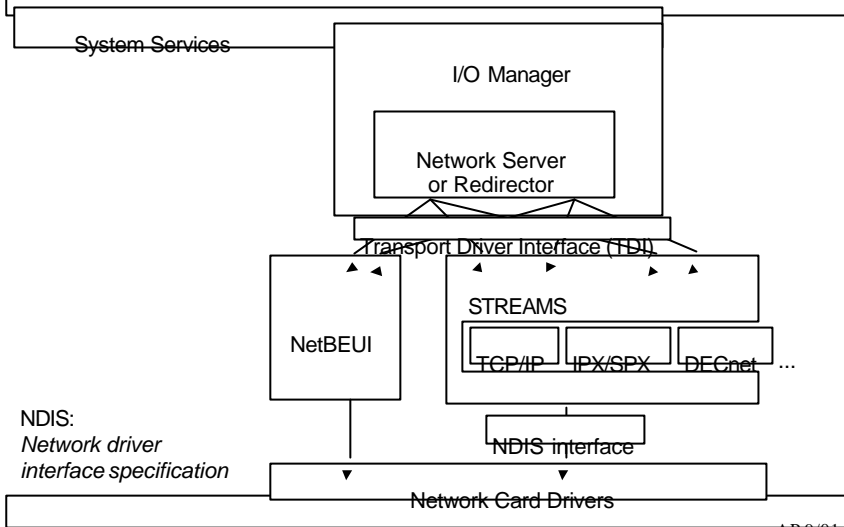

TDI operation

1. Client allocates/formats an *address open* TDI IRP
 - TDI returns file object known as address object
 - Equivalent to winsock bind() function
2. Client allocates/formats *connection open* TDI IRP
 - TDI returns *connection object* (equiv. to socket())
3. Client issues *associate address* TDI IRP
 - This associates connection object to the address object
4. TDI client issues *listen* TDI IRP and *accept* TDI IRP
 - Equivalent to winsock listen() and accept()
5. Other TDI client issues *connect* TDI IRP
 - Specifying connection object as parameter
 - Equivalent to winsock connect()

AP 9/01

TDI operation (contd.)

- TDI also supports connectionless protocols (UDP)
- TDI supports registering *event callbacks*
 - Functions directly invoked by TDI (event notification)
 - No need to pre-allocate resources (buffers)
- TDI uses NDIS 5 interface to talk to drivers
 - Network Driver Interface Specification (Microsoft/3Com spec., 1989)
 - NDIS hides IRP mechanism from network driver:
same driver may work for Windows 2000/Consumer Windows
 - NDIS 4 did serialization of requests on driver level (MP scalability ??)
 - NDIS 5 allows driver to specify concurrency constraints

AP 9/01

NDIS 5 Features

- Report whether network medium is active
 - TCP/IP uses this information to reevaluate DHCP addressing info.
- TCP/IP task offloading
 - Packet checksums or IPsec can be handled at network adaptor level
- Fast packet forwarding
 - Network adaptor may perform routing (without delivering them to CPU)
- Wake-on-LAN
- Connection-oriented NDIS
 - Manage connection-oriented media such as Asynchronous Transfer Mode (ATM) devices

AP 9/01

Transports supported by TDI

- NetBEUI transport
 - NetBIOS Extended User Interface – LAN transport protocol developed by IBM to operate underneath the NetBIOS interface
- TCP/IP transport
 - Transmission Control Protocol/Internet Protocol – wide-area protocol developed for U.S. DoD to connect heterogeneous (UNIX) systems
 - Supports STREAMS – UNIX Sys V env. for portable transport drivers (!!)
- IPX/SPX transport
 - Internet Packet Exchange/Sequenced Packet Exchange – protocols used by Novell's NetWare (connectionless comm.)
- DECnet transport
 - Proprietary protocol used by Digital Equipment Corporation
- AppleTalk transport
- XNS transport
 - Xerox Network Systems – was used in early Ethernet networks

AP 9/01

Microsoft TCP/IP - Overview

- Core protocol elements, services, and the interfaces between them.
- Transport Driver Interface (TDI) and Network Device Interface (NDIS) are public
 - specifications are available from Microsoft.
- A number of higher level interfaces available to user-mode applications.
 - The two most commonly used are Windows Sockets and NetBIOS.

AP 9/01

Windows NT TCP/IP Network Model

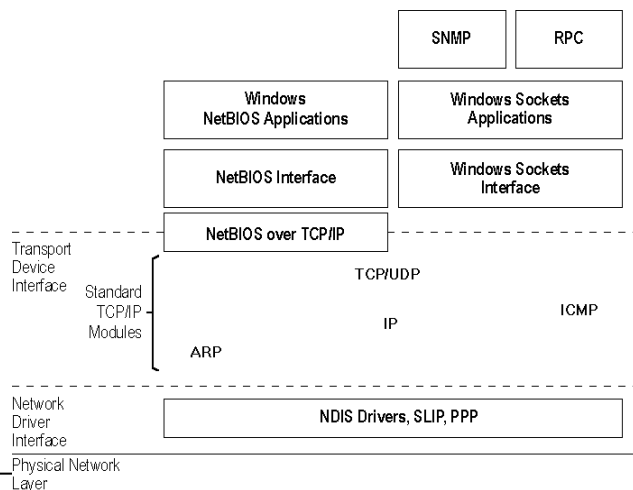

AP 9/01

TCP/IP Implementation in Windows 2000

- Support for Standard Features
 - Ability to bind to multiple network cards with different media types
 - Logical multihoming
 - Internal IP routing capability
 - IGMP (IP Multicasting) support
 - Duplicate IP address detection
 - Multiple default gateways
 - Dead gateway detection
 - Automatic Path Maximum Transmission Unit (PMTU) discovery
- Performance Enhancements
 - Greatly reduced broadcast traffic
 - Shorter code paths/reduced CPU utilization
 - Self-tuning features

AP 9/01

TCP/IP in Windows 2000 (contd.)

- Services Available
 - Dynamic Host Configuration Protocol (DHCP) client and server
 - Windows Internet Name Service (WINS), a NetBIOS name server
 - Domain Name Server (DNS) (added in Windows NT 4.0)
 - Point-to-Point Tunneling Protocol (PPTP) used on dial-up networks
 - Dial-up (PPP/SLIP) support
 - TCP/IP network printing (lpr/lpd)
 - SNMP agent
 - Wide Area Network (WAN) browsing support
 - High-performance Microsoft Internet Information Server
 - Basic TCP/IP connectivity utilities, including: finger, FTP, rcp, rexec, rsh, Telnet, and tftp
 - Server software for simple network protocols, including: Character Generator, Daytime, Discard, Echo, and Quote of the Day
 - TCP/IP management and diagnostic tools, including: arp, hostname, ipconfig, ipq, nbtstat, netstat, ping, route, and tracertr

- NetBIOS **interface**
- Windows Sockets interface
- Remote Procedure Call (RPC)
- Network Dynamic Data Exchange (NetDDE)

AP 9/01

Windows Sockets 2 in Windows 2000

Windows Sockets 2 Features

- **Access to protocols other than TCP/IP**
 - Windows Sockets 2 allows an application to use the familiar socket interface to achieve simultaneous access to a number of installed transport protocols
- **Overlapped I/O with scatter/gather**
 - Windows Sockets 2 incorporates the overlapped paradigm for socket I/O and incorporates scatter/gather capabilities as well, following the model established in Win32 environments
- **Protocol-independent name resolution facilities:**
 - Windows Sockets 2 includes a standardized set of functions for querying and working with the myriad of name resolution domains that exist today (for example DNS, SAP, and X.500)

AP 9/01

Windows Sockets 2 (contd.)

- **Protocol-independent multicast and multipoint:**
 - Windows Sockets 2 applications discover what type of multipoint or multicast capabilities a transport provides and use these facilities in a generic manner.
- **Quality of service**
 - Windows Sockets 2 establishes conventions applications use to negotiate required service levels for parameters such as bandwidth and latency. Other QOS-related enhancements include mechanisms for network-specific QOS extensions.
- **Other frequently requested extensions**
 - Windows Sockets 2 incorporates shared sockets and conditional acceptance; exchange of user data at connection setup/teardown time; and protocol-specific extension mechanisms.

AP 9/01

Networking APIs (summary)

- Named Pipes and Mailslots
- Windows Sockets (winsock)
 - Extensible API on Windows 2000 (via service provider interface – SPI)
 - Transport service providers: TCP/IP, NetBEUI, AppleTalk, IPX/SPX, ATM, IrDA (Infrared Data Association)
 - Namespace service providers: DNS, Active Directory, IPX/SPX
- Remote Procedure Call (DCE RPC)
- Common Internet File System (CIFS – SMB)
- Network Basic Input/Output System (NetBIOS)
- Telephony API
 - TAPI 2.2 for C Apps, TAPI 3.0 for COM Apps
- Component Object Model – COM+
 - Message Queuing

AP 9/01

Layered Network Services

- Remote Access
 - Dial-up remote access via Telco-infrastructure
 - Virtual private network (VPN):
virtual point-to-point connection via IP network (Internet)
- Active Directory: Windows 2000 impl. of LDAP
(Lightweight Directory Access Protocol)
 - LDAP C language API
 - Active Directory Service Interfaces (ADSI) – COM Interface to AD
 - Messaging API (MAPI) – compatibility with Exchange/Outlook
 - Security Account Manager (SAM) APIs interface with auth. packages
 - MSVL_0 (\Winnt\System32\Msvl_0.dll – legacy LanManager auth.)
 - Kerberos (\Winnt\System32\Kdcsvc.dll – Kerberos auth.)
 - NT 4.0 clients access AD via Net APIs through SAM

AP 9/01

Layered Network Services (contd.)

- **Network Load Balancing**
 - With Windows 2000 Advanced Server, NDIS intermediate driver
 - Useful for certain TCP/IP-based cluster-aware applications
- **File Replication Service (FRS)**
 - Used to replicate a domain controller's \SYSVOL directory
 - Relies on NTFS change journal
- **Distributed File System (DFS)**
 - Location-transparent resource access
- **TCP/IP Extensions**
 - Network Address Translation (IP masquerading)
 - Internet Protocol Security (IPsec)
 - Quality-of-Service